



# POTATO PEELER PPC-6+

Output: 6 Kg. per cycle. Equipped with attachment drive to power accessories.



Timer (min-max): 0' - 6'  
Plate speed: 317 rpm  
Total loading: 550 W (1~) / 550 W (3~)

### External dimensions (WxDxH)

- ✓ Width: 395 mm
- ✓ Depth: 700 mm
- ✓ Height: 433 mm

### External dimensions with stand

- ✓ Width with stand: 411 mm
- ✓ Depth with stand: 700 mm
- ✓ Height with stand: 945 mm

Net weight: 37 Kg

Noise level (1m.): 70 dB(A)  
Background noise: 32 dB(A)

### AVAILABLE MODELS

1000385	Potato peeler PPC-6	230/50/1
1000430	Potato peeler PPC-6+	230-400/50/3 ·550W
1000431	Potato peeler PPC-6+	230/50/1 ·550W
1000434	Potato peeler PPC-6+	220/60/1

\* Ask for special versions availability

## SALES DESCRIPTION

Aluminium made potato peeler.

Aluminium body potato peeler. Abrasive peeling. The abrasive is highly resistant and long lasting.

- ✓ Base Plate and chamber walls lined with abrasive.
- ✓ Aluminium body.
- ✓ Equipped with attachment drive to power accessories.
- ✓ Directable cylinder.
- ✓ Integral control panel complete with on/off push buttons and a 0-6 minute timer.

## INCLUDES

- ✓ Attachment drive to power accessories.

## OPTIONAL

- Stainless steel floor stand.
- Filter with no-foam feature.
- Vegetable preparation attachment CR-143.
- Potato masher attachment P-132.
- Meat mincer attachment HM-71.
- Water inlet kit (2003971).

## ACCESSORIES

- Vegetable preparation attachment CR-143
- Meat mincer attachment HM-71
- Potato masher attachment P-132
- Stands for potato peelers PP / PPC
- Filters for potato peelers PP / PPC

## SPECIFICATIONS

Hourly production: 120 Kg / 150 Kg  
Capacity per load: 6 Kg



DYNAMIC PREPARATION  
COMMERCIAL POTATO PEELERS

product sheet  
updated 22/09/2022



# POTATO PEELER PPC-6+

Output: 6 Kg. per cycle. Equipped with attachment drive to power accessories.



DYNAMIC PREPARATION  
COMMERCIAL POTATO PEELERS

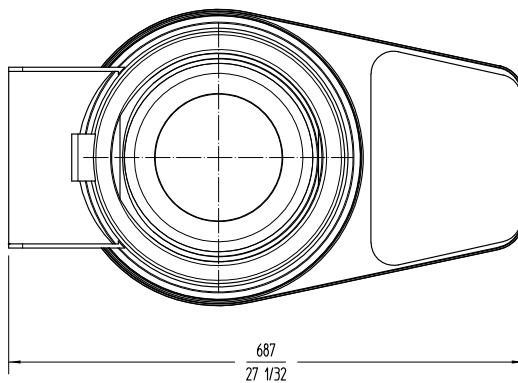
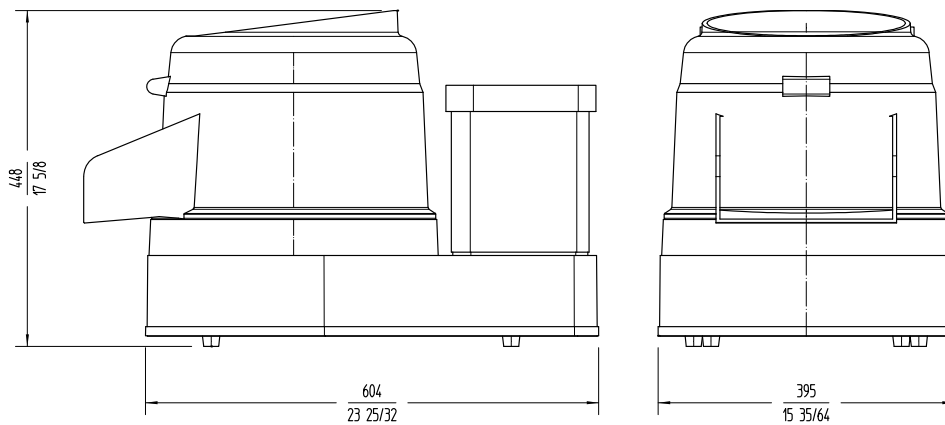

**sammic** | [www.sammic.com](http://www.sammic.com)  
Food Service Equipment Manufacturer

Polígono Basarte, 1. phone +34 943 15 72 36  
20720 Azkoitia, Spain [sales@sammic.com](mailto:sales@sammic.com)



Project	Date
Item	Qty
Approved	

product sheet  
updated 22/09/2022