



VACUUM SEALER SU-810LL

Floorstanding unit. 100m³/h. 848+848 mm.



SALES DESCRIPTION

Two sealing bars (848+848 mm.)
100 m³/h Busch vacuum pump.
Vacuum controlled by sensor.

- ✓ Powered by Busch.
- ✓ Vacuum controlled by sensor.
- ✓ Vacuum PLUS.
- ✓ LCD colour screen: all information at a glance.
- ✓ Backlit touch keyboard.
- ✓ Programmable: 25-programme memory. Blocking option.
- ✓ "Pause" button.
- ✓ Phased vacuum programme.
- ✓ Detection of the evaporation of liquids.
- ✓ Double seal.
- ✓ Cordless sealing bar.
- ✓ Progressive decompression.
- ✓ Vac-Norm ready with Automatic decompression.
- ✓ Stainless steel body and chamber.
- ✓ Damped transparent lid of high durability polycarbonate.
- ✓ Dry-oil programme for drying the pump.
- ✓ Working hours counter for oil changes.
- ✓ Safety system with protection against vacuum failure.
- ✓ NSF-listed.

INCLUDES

- ✓ BUSCH pump.
- ✓ Sensor Controls.
- ✓ 25 programmable settings.
- ✓ Vacuum PLUS: up to 10 seconds of extra vacuum pull.
- ✓ Soft air function.
- ✓ Clear methacrylate lid.
- ✓ "PAUSE" function.
- ✓ Liquid detection system.
- ✓ Dry oil cycle.
- ✓ NSF Approved.
- ✓ Filling plate.

OPTIONAL

- Inert gas
- Sealing plus
- Printer
- Bluetooth connectivity
- Vacuum packing bags
- External vacuum kit for Vac-Norm, containers and accessories
- Bag cutting kit
- Support for liquid packaging
- Additional filling plates

ACCESSORIES

- Bag cutting kits
- Filling plates
- Liquid insert plates
- Vac-norm external vacuum kits
- Vac-norm containers
- Smooth bags for vacuum packing
- Thermal labels for CG2 / RB printer
- RB Desktop printer for SU vacuum packing machines
- Thermal transfer labels for RB printer

SPECIFICATIONS

Pump capacity: 100 m³/h
 Pump capacity (60 Hz): 120 m³/h
 Bar length: 848 mm + 848 mm
 Total loading: 2200 W
 Vacuum pressure (maximum): 0.5 mbar

Plug: --
 Electrical connection: --

Internal dimensions

- ✓ Width: 864 mm
- ✓ Depth: 603 mm
- ✓ Height: 215 mm

External dimensions (WxDxH)

- ✓ Width: 960 mm
- ✓ Depth: 757 mm
- ✓ Height: 998 mm

Net weight: 250 Kg

Noise level (1m.): 75 dB(A)
 Background noise: 32 dB(A)

Crated dimensions

840 x 1060 x 1200 mm
 Gross weight: 275 Kg

FOOD PRESERVATION AND SOUS-VIDE
VACUUM PACKING MACHINES - "SENSOR ULTRA" LINE

product sheet
updated 04/03/2022



SAMMIC, S.L.
Bassarre, 1 - 20720 Azzovita
www.sammic.com



VACUUM SEALER SU-810LL

Floorstanding unit. 100m³/h. 848+848 mm.



AVAILABLE MODELS

- 1140955 Vacuum packing machine SU-810 LL 400/50-60/3N
- 1140956 Vacuum packing machine SU-810 LL 230-400/50/3N -C-
- 1140957 Vacuum packing machine SU-810G LL 400/50-60/3N
- 1140958 Vacuum packing machine SU-810P LL 400/50-60/3N
- 1140959 Vacuum packing machine SU-810+ LL 400/50-60/3N
- 1140960 Vacuum packing machine SU-810P+ LL 400/50-60/3N
- 1140961 Vacuum packing machine SU-810GP LL 400/50-60/3N
- 1140962 Vacuum packing machine SU-810G+ LL 400/50-60/3N
- 1140963 Vacuum packing machine SU-810GP+ LL 400/50-60/3N
- 1140985 Vacuum packing machine SU-810 LL 208-240/60/3
- 1140986 Vacuum packing machine SU-810 LL 208-240/60/3 -C-
- 1140987 Vacuum packing machine SU-810G LL 208-240/60/3
- 1140988 Vacuum packing machine SU-810P LL 208-240/60/3
- 1140989 Vacuum packing machine SU-810+ LL 208-240/60/3
- 1140990 Vacuum packing machine SU-810P+ LL 208-240/60/3
- 1140991 Vacuum packing machine SU-810GP LL 208-240/60/3
- 1140992 Vacuum packing machine SU-810G+ LL 208-240/60/3
- 1140993 Vacuum packing machine SU-810GP+ LL 208-240/60/3
- 1141016 Vacuum packing machine SU-810 LL 220/60/3
- 1141017 Vacuum packing machine SU-810 LL 220/60/3 -C-
- 1141018 Vacuum packing machine SU-810G LL 220/60/3
- 1141019 Vacuum packing machine SU-810P LL 220/60/3
- 1141020 Vacuum packing machine SU-810+ LL 220/60/3
- 1141021 Vacuum packing machine SU-810P+ LL 220/60/3
- 1141022 Vacuum packing machine SU-810GP LL 220/60/3
- 1141023 Vacuum packing machine SU-810G+ LL 220/60/3
- 1141024 Vacuum packing machine SU-810GP+ LL 220/60/3

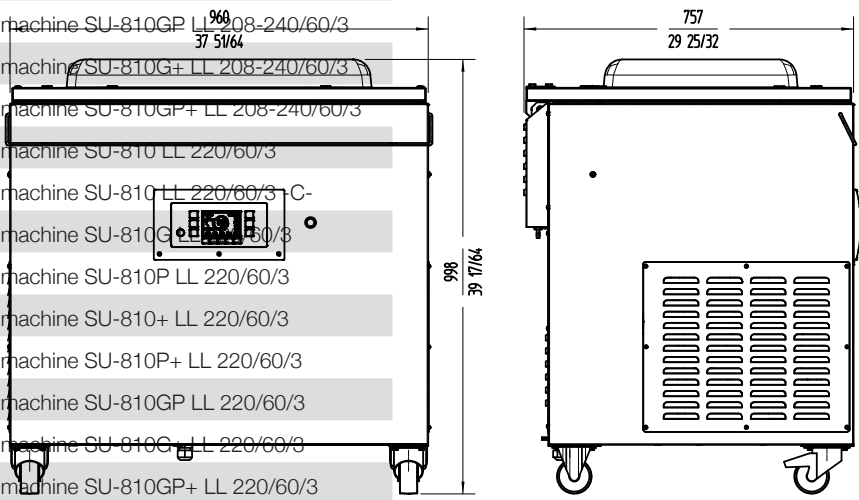

* Ask for special versions availability

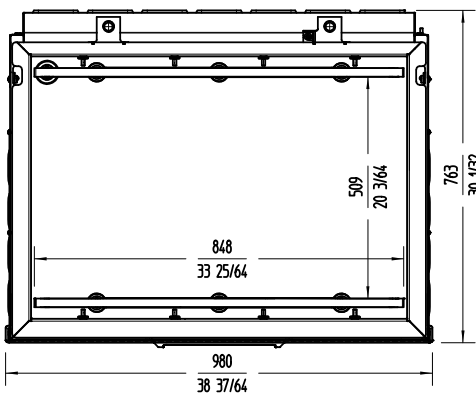

FOOD PRESERVATION AND SOUS-VIDE
VACUUM PACKING MACHINES - "SENSOR ULTRA" LINE

sammic www.sammic.com Food Service Equipment Manufacturer Polígono Basarte, 1. phone +34 943 15 72 36 20720 Azkoitia, Spain sales@sammic.com		Project	Date
		Item	Qty
		Approved	

product sheet
updated 04/03/2022