



# JOSPER CHARCOAL BROILER OVEN HJA



## TECHNICAL INFORMATION

Recommended for ±	40 diners	
Fire up time	25 min average	
Charcoal daily consumption	6 to 8 kg	13.2 to 17.6 lb
Performance	7h	
Production per hour	25 kg average	55.1 lb average
Broiling temperature	250 to 350 °C	482 to 662 °F
Grill rack capacity in GN trays	1xGN1/1	
Nominal heat output	7,5 kW	10.06 hp
Flue gas mass flow	11.91 g/s	0.42 oz/s
Smoke temperature	288 °C	550 °F
Net weight	173 kg	381.4 lb

## HJA-20

The new Class A charcoal broiling oven is much more than a grill and an oven in a single machine. It is a unique equipment working 100% with charcoal, with a unique closed barbecue design, different levels of grilling, both flexible and robust, easy to use, with a front opening door, vent system for temperature control and double rack to gain productivity.

Class A efficiency improvements include hydraulic door retention, thermal insulation, new upper tempering area, greater accessibility, a more compact design and easy clean system. These upgrades result in an exponential increase in the quality and quantity of its production and the oven's final performance.

## INSTALLATION

Recommended installation height	850 mm	33 1/2 in
Clearance with non-flammable equipment	100 mm	4 in
Clearance with flammable equipment	300 mm	12 in
Exhaust rate	2500 m3/h	1471 cfm

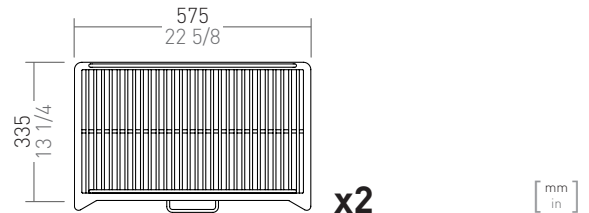

## ACCESSORIES INCLUDED

Vent · Firebreak · Firebreak hat · 2 Grill racks · Tongs · Wire brush · Poker for coal · Ash pan



Ed.10.2020 - Jospers reserves the right to make modifications to catalogues, pricelists and promotional material according to the development and improvements applied to its equipment.



# JOSPER CHARCOAL OVEN HJA

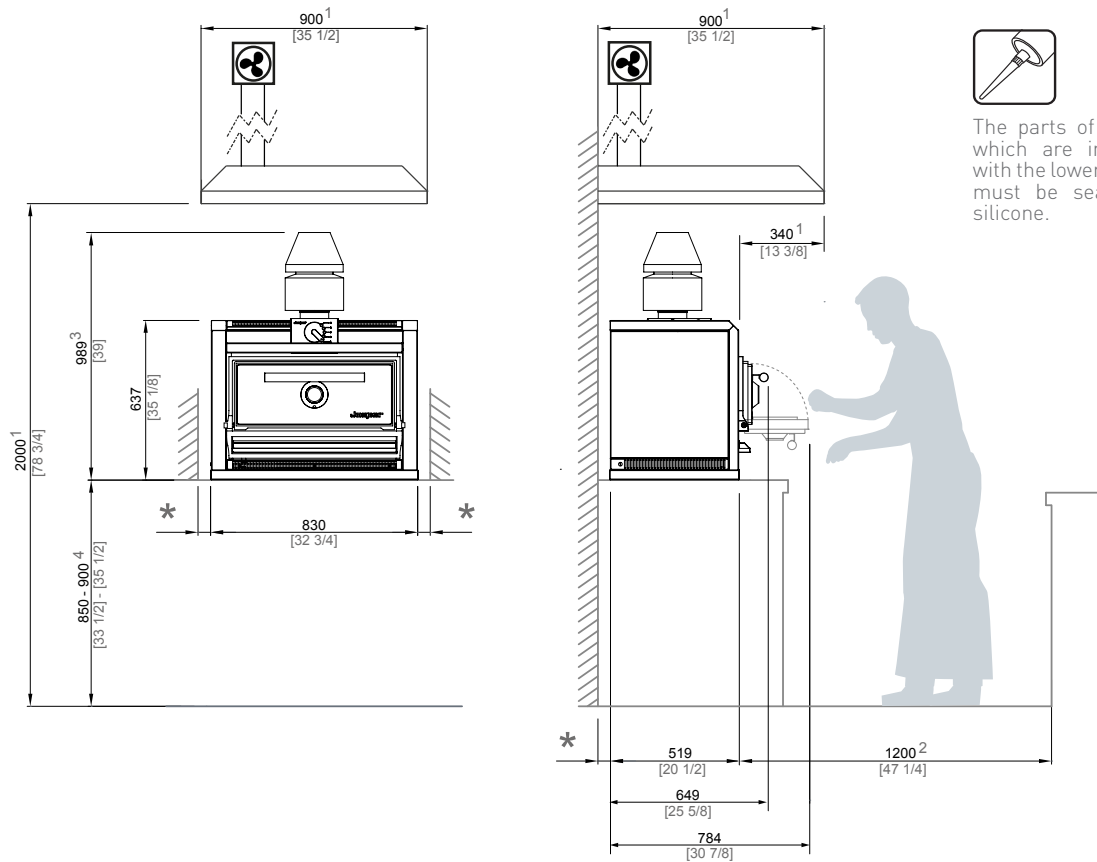
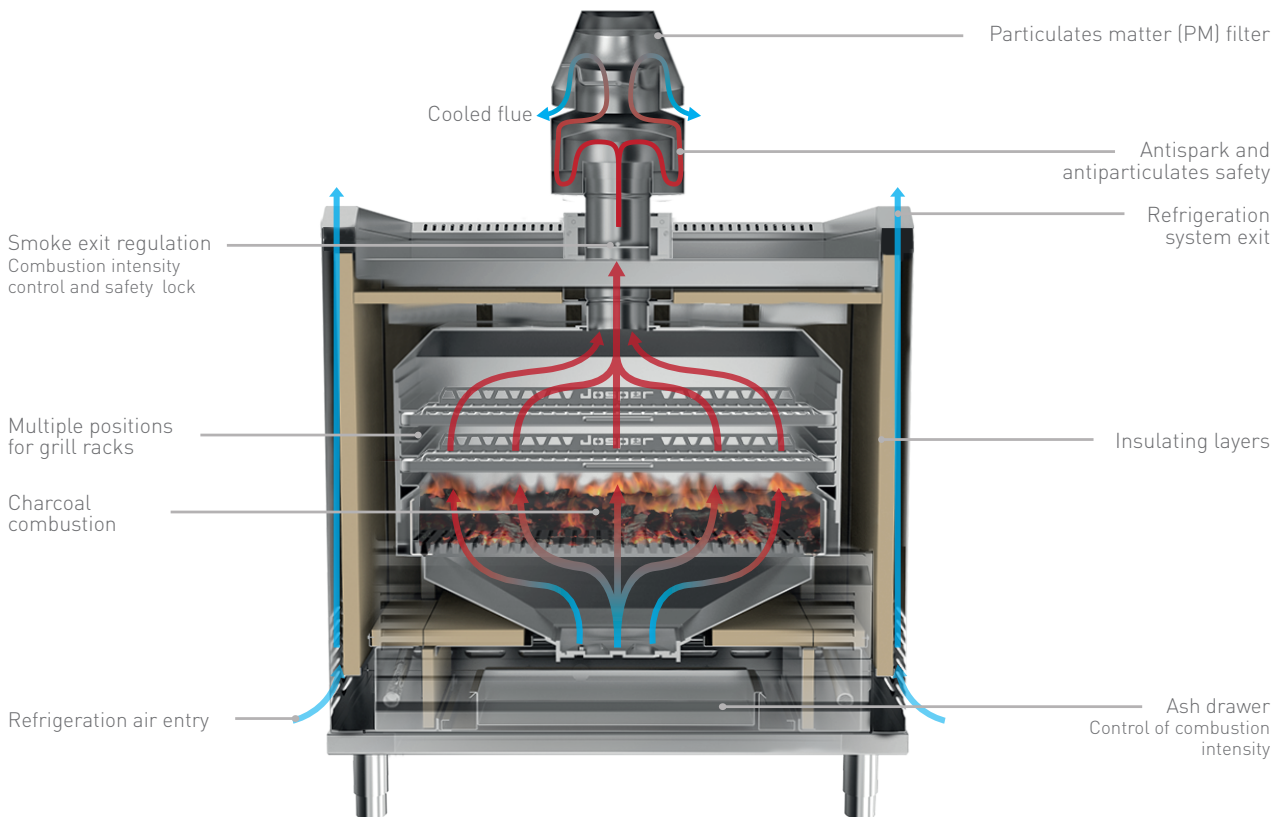

The parts of the oven which are in contact with the lower furniture must be sealed with silicone.

\* MINIMUM DISTANCE TO FLAMMABLE ELEMENTS: 300 mm [12 in] / RECOMMENDED DISTANCE TO ANOTHER ELEMENTS: 100 mm [4 in]

1 RECOMMENDED HOOD'S MINIMUM DIMENSIONS

2 RECOMMENDED CHEF'S WORKING SPACE

3 THIS DISTANCE MAY BE MODIFIED BY THE SMOKE OUTLET SET CONFIGURATION.

4 RECOMMENDED INSTALLATION HEIGHT.

[ mm  
in ]

